

XN Series - XN 8.0.6

User Manual

Rev 1.0.9

Publication date: 29th May 2026

SKU Number: XN806-SPKR-0000-7531

Tech Support : support@atomikaudio.com

CONTENTS

WARNINGS AND IMPORTANT SAFETY INSTRUCTIONS.....	4
XN SERIES OVERVIEW.....	5
DATASHEET.....	6
INTERNAL WIRING SCHEMATIC.....	7
VISUAL IDENTIFICATION OF PARTS AND ACCESSORIES.....	8
ACCESSORIES.....	9
Pan Tilt Clamp, Swivel Clamp, C-Clamp.....	9
Passive Crossover Assembly, Weatherproof Sleeve, Mounting Pole.....	10
Top Hat, Top Hat Plate, Ceiling Bracket.....	11
INSTALLATION DETAILS.....	12
Gang Box / Back Box Installation.....	12
D1, D2.....	13
D3, D4.....	14
D5, D6.....	15
D7, D8.....	16
D9, D10.....	17
D11.....	18
WARRANTY.....	19
CONTACTS.....	21

WARNINGS! IMPORTANT SAFETY INSTRUCTIONS

Thank you for your confidence in purchasing the Atomik XN series of sound systems.

Please read the owner's/installation manual carefully to ensure optimum performance of the sound system as intended by the designer.

Please ensure use of the XN series of loudspeakers with their dedicated DSP presets to achieve their optimum best.

Atomik will not be responsible for damage caused by improper use or modifications to this product.

Atomik will not be responsible for damage caused by improper installation or optimization of this product.

Clean only with dry cloth.

Keep this product away from moisture and water.

Do not expose this product to direct rain.

Do not expose this product to direct sunlight.

Keep this product away from Hard Drives/Hard Disks.

Do not install near any heat sources such as radiators, stoves, or other heat-producing apparatus.

Use only accessories specified/supplied by Atomik.

Refer all servicing to qualified service personnel.

No user serviceable parts inside.

DANGER!
HIGH SPL MAY CAUSE HEARING DAMAGE

CAUTION!
RISK OF ELECTRICAL SHOCK
DO NOT OPEN

XN SERIES - OVERVIEW

Introduction

The XN Series is a set of full range, point-source loudspeakers and powerful subwoofers.

Our XN Series speakers are well-known for their versatility and high-resolution sound.

They are the top choice for professionals in live performances, audio rental services, nightclub installations, pubs, bars, cafes and lounges.

The XN Series delivers clear and detailed sound even at very high volumes, which is rare in the pro audio world. They keep the sound quality intact, ensuring every detail is heard. This makes them essential for any place where sound quality is important.

SKU Number: XN806-SPKR-0000-7531

Description

The Atomik XN 8.0.6 is a 2 way passive full range loudspeaker, designed for the pro-audio rental and fixed installation markets. This point source box is a high output loudspeaker with a 1" HF driver on a 80x50 horn and an 8" LF driver, exhibiting excellent low frequency performance for a compact enclosure. It can be used as a standalone speaker or paired with any of the Atomik subwoofers.

Features

- Very high SPL output for a compact 8" full range loudspeaker.
- Exceptional fidelity & high resolution loudspeaker system.
- Very smooth power response.
- High sensitivity design.
- Wide dispersion pattern.
- Dual Neutrik NL4 connectors.
- Easily compatible with the XN 18.0.2 Subwoofer or the XN 218.0.2 Subwoofer.
- Heavy duty 16mm marine plywood enclosure.
- 2mm thick steel grill with an acoustic micro-foam backing.
- 3 x M8 rigging points for easy flying.
- Passive crossover.

Technical specifications

- HF Driver - 1" HF ferrite compression driver with a 44 mm voice coil and polyimide diaphragm.
- LF Driver - 8" LF ferrite driver with a 65.5 mm voice coil.
- HF Horn - 80 x 50 degree nominal coverage pattern, rotatable HF horn.
- Enclosure - Ported
- Axial Sensitivity - 92.0dB @ 1W/1m
- Maximum SPL - 120.0dB Peak SPL (Measured-AES75-2022 M-Noise)
 126.6dB Peak SPL inf(Measured-AES75-2022 M-Noise)
 120.0dB SPL peak, 126.6dB SPL peak inf (Unweighted)
 120.3dB SPL peak, 123.3dB SPL peak inf (A weighted)
 119.7dB SPL peak, 125.1dB SPL peak inf (C weighted))
- Power - Max 300 watts long term continuous / Peak 600 watts
- Nominal Impedance - 8 ohms 6.7 ohms passive
- Frequency Response - 3dB 60Hz to 18kHz
- Frequency Response - 10dB 50Hz to 20kHz
- Dimensions in mm & in WxHxD - 270mm x 448mm x 306mm,
 10.6" x 17.6" x 12"
- Weight -15.38kg / 33.9lbs

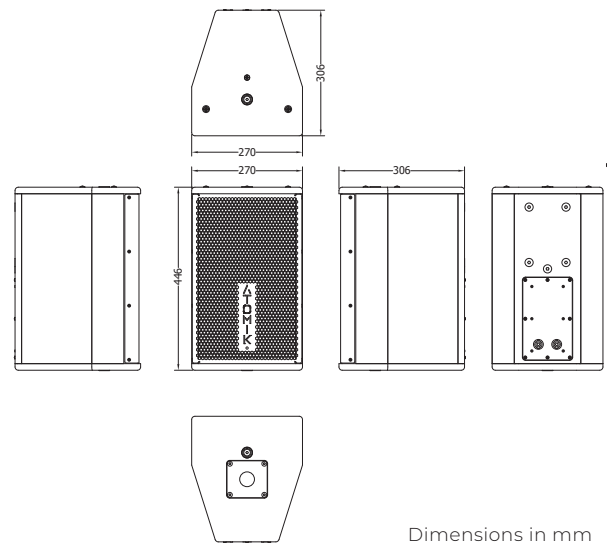
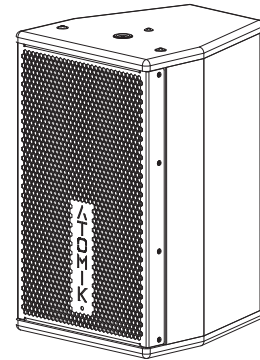

Accessories

- Pan Tilt Clamp
- Swivel Clamp
- C-Clamp

Applications

- Rental
- HOW
- Clubs

Accessories

- Weatherproof Sleeve
- Ceiling Bracket
- Top Hat

Applications

- Bars
- Restaurants
- Auditoriums

INTERNAL WIRING SCHEMATIC

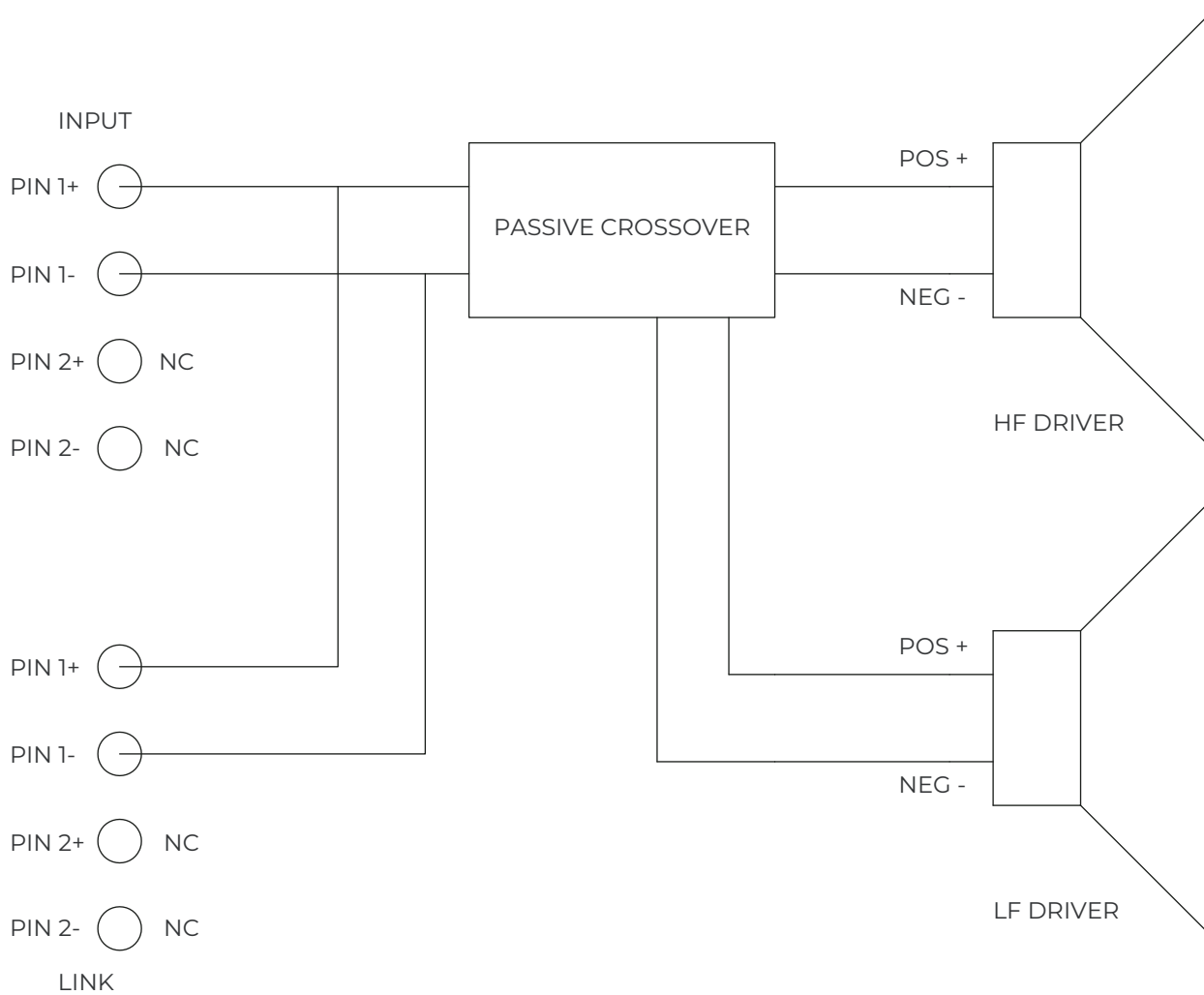

*NC - NOT CONNECTED

VISUAL IDENTIFICATION OF PARTS & ACCESSORIES

1 - Locking screw for C-Clamp

2 - Fixing screw for C-Clamp

3 - Flying points

4 - Locking screw for C-Clamp

5 - Fixing screw for C-Clamp

6 - Flying points

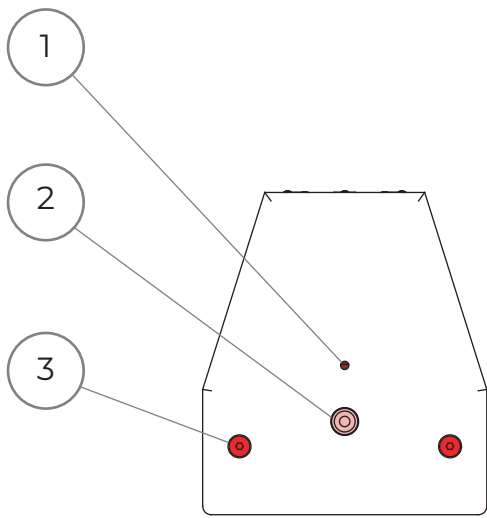

TOP VIEW

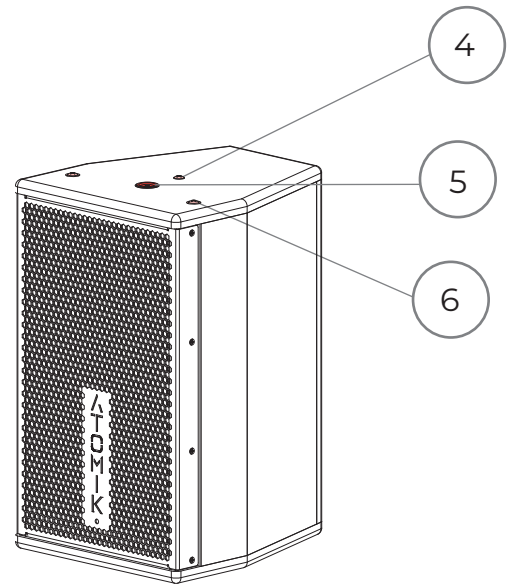

ISO VIEW

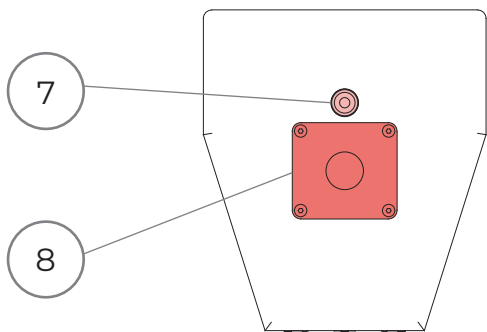

BOTTOM VIEW

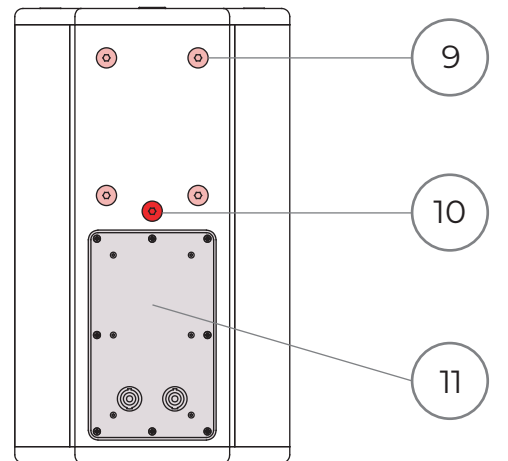

REAR VIEW

7 - Fixing screw for C-Clamp

8 - Top hat

9 - Screws for swivel clamp

10 - Flying point

11 - Passive crossover

ACCESSORIES - XN 8.0.6

Pan Tilt Clamp

For wall mounted installations.

SKU: XN806-CLMP-PANT-BLK-8147

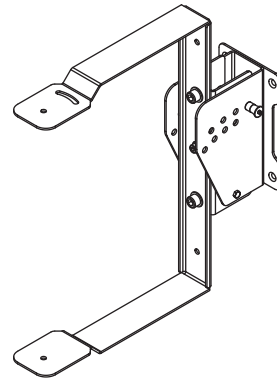

Swivel Clamp

For wall mounted installations.

SKU: XN806-CLMP-SWL-BLK-5237

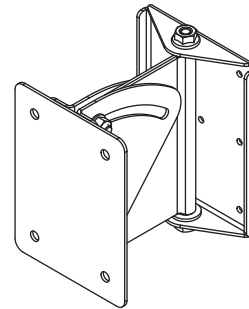

C-Clamp

For wall/ceiling mounted installations.

SKU: XN806-CLMP-C-BLK-5689

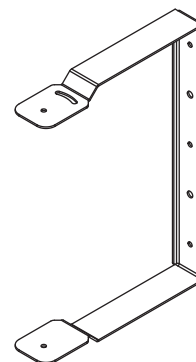

ACCESSORIES - XN 8.0.6

Passive Crossover Assembly

Field replaceable passive crossover assembly.

SKU: XN806-XVR-08-5397

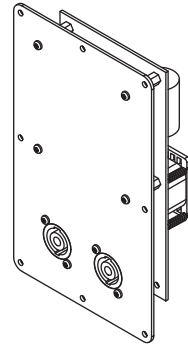

Weatherproof Sleeve

Weatherproof metal sleeve for protection from natural elements.

SKU: XN806-SLV-BLK-1934

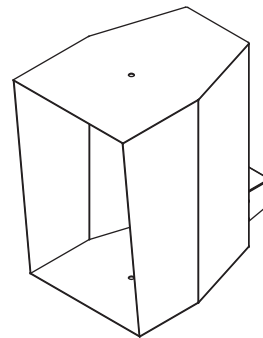

Mounting Pole

For pole mounting on sub-woofers.

SKU: XN806-POL-BLK-7984



ACCESSORIES - XN 8.0.6

Top Hat

For pole mounting.

SKU: XN806-THAT-BLK-3451

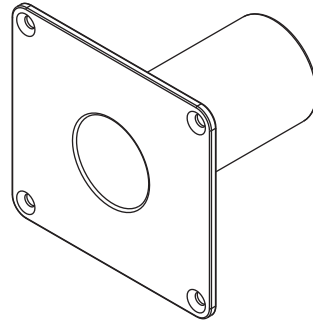

Top Hat Plate

To cover the top hat hole when not in use.

SKU: XN806-THATP-BLK-7683

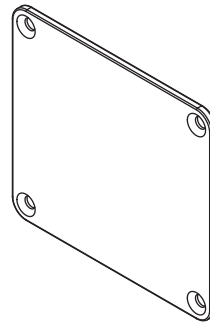

Ceiling Bracket

For ceiling mounted installations.

SKU: XN806-CBR-BLK-4382

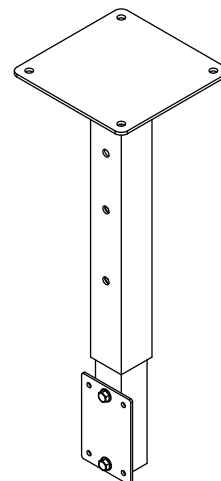

INSTALLATION DETAILS

GANG BOX / BACK BOX INSTALLATION

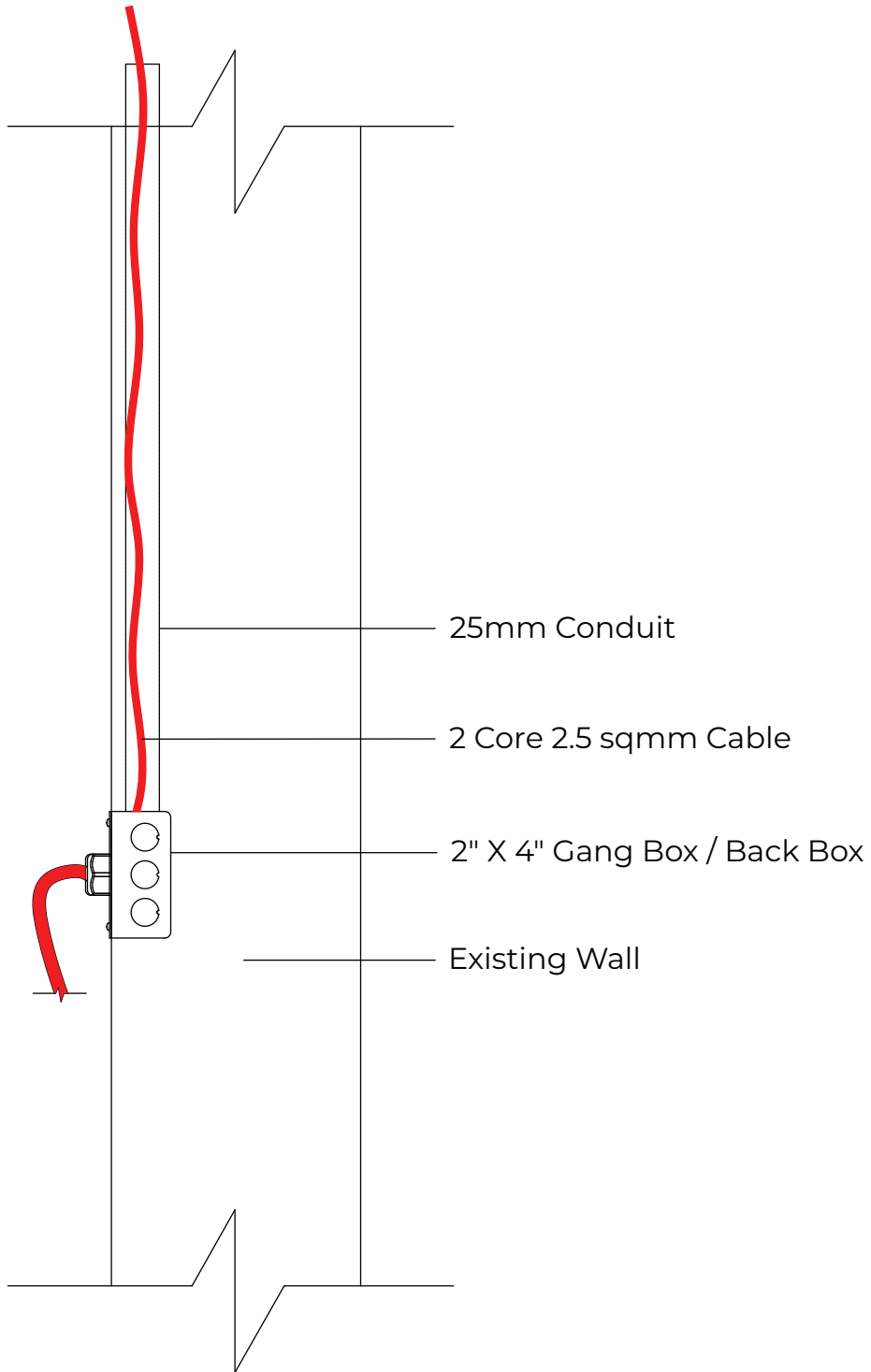

INSTALLATION DETAILS - XN 8.0.6

D1

Accessory Used - C-Clamp
Installation Type - Wall Mounted
Installation Mode - Landscape

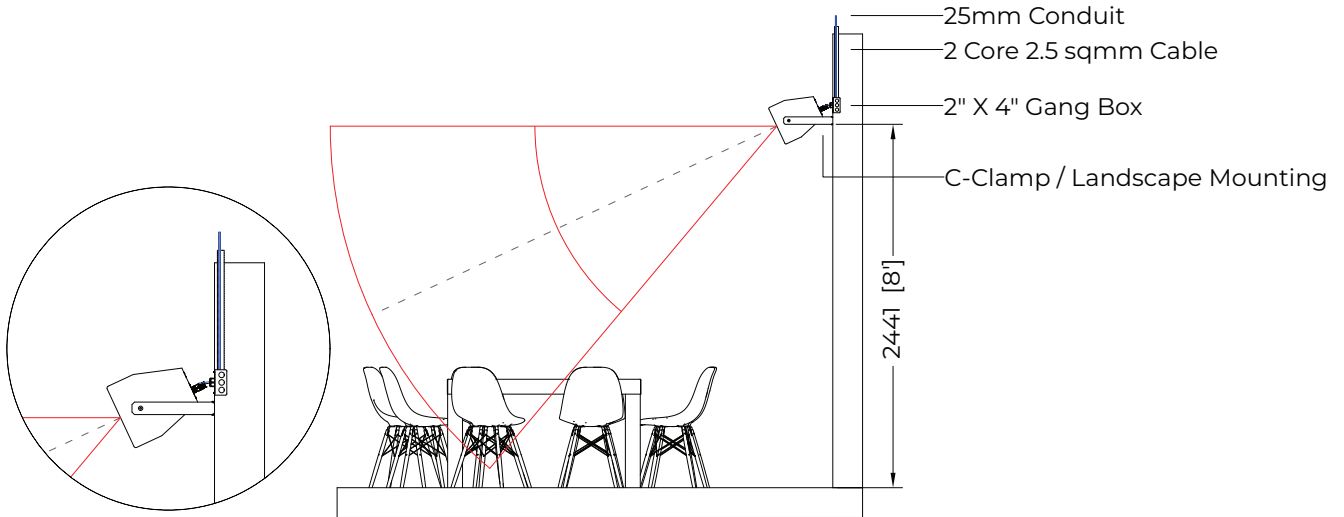

D2

Accessory Used - C-Clamp
Installation Type - Wall Mounted
Installation Mode - Portrait

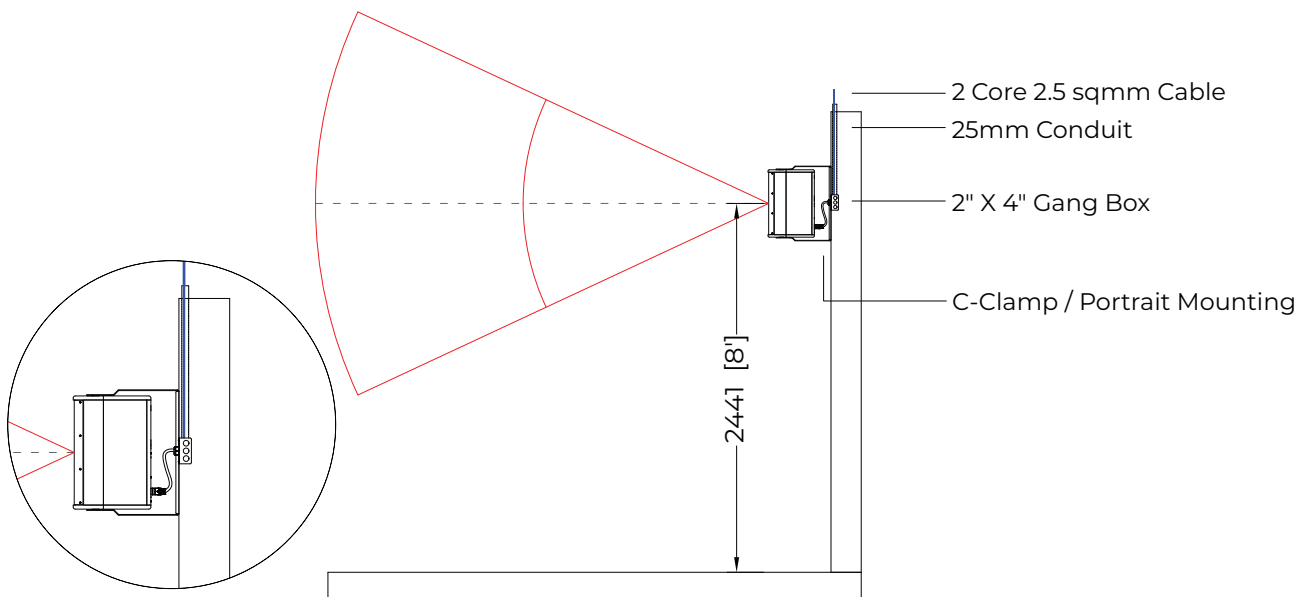

INSTALLATION DETAILS - XN 8.0.6

D3

Accessory Used - C-Clamp
Installation Type - Ceiling Mounted
Installation Mode - Landscape

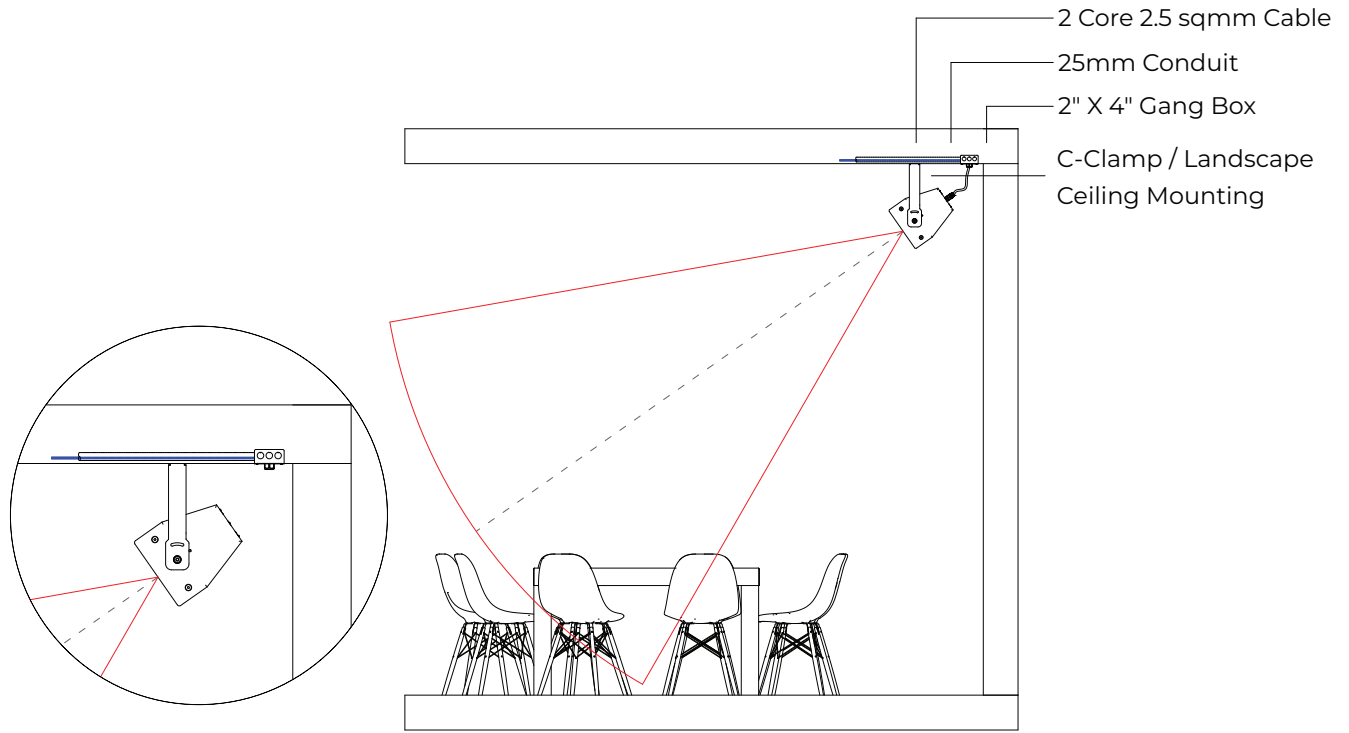

D4

Accessory Used - Pan Tilt Clamp
Installation Type - Wall Mounted
Installation Mode - Portrait

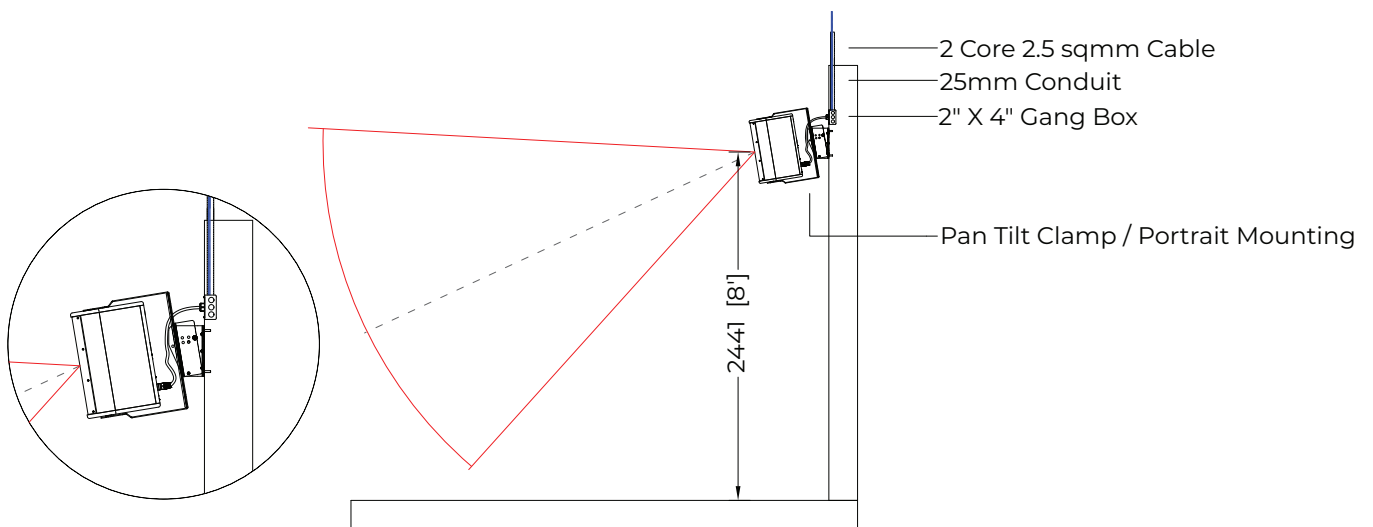

INSTALLATION DETAILS - XN 8.0.6

D5

Accessory Used - Pan Tilt Clamp
Installation Type - Ceiling Mounted
Installation Mode - Portrait

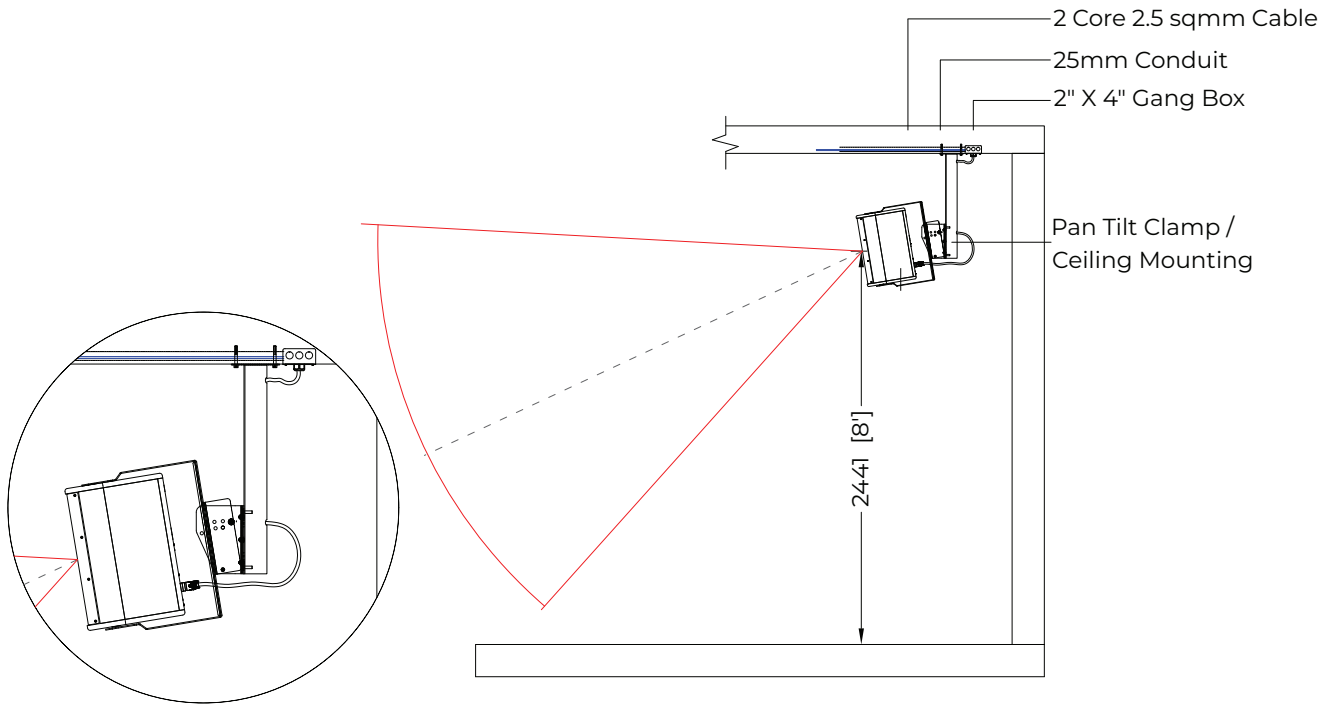

D6

Accessory Used - Pan Tilt Clamp With Weatherproof Sleeve
Installation Type - Ceiling Mounted
Installation Mode - Portrait

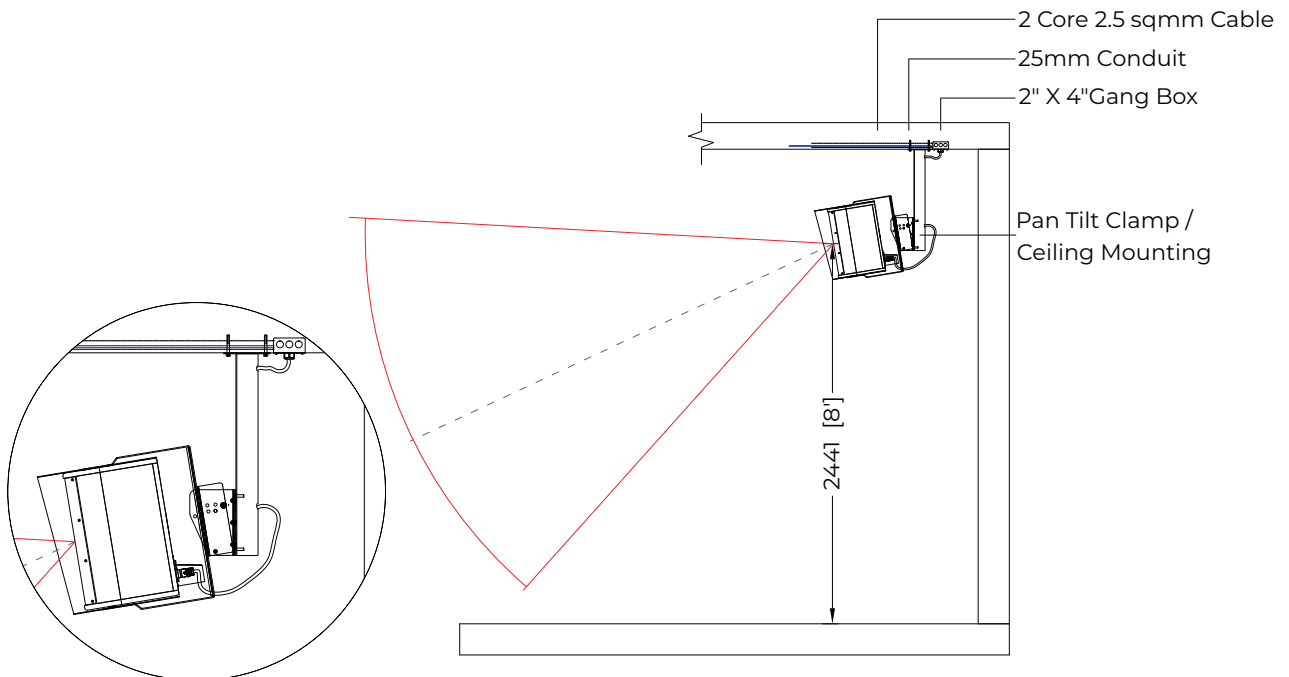

INSTALLATION DETAILS - XN 8.0.6

D7

Accessory Used - Swivel Clamp
Installation Type - Wall Mounted
Installation Mode - Portrait

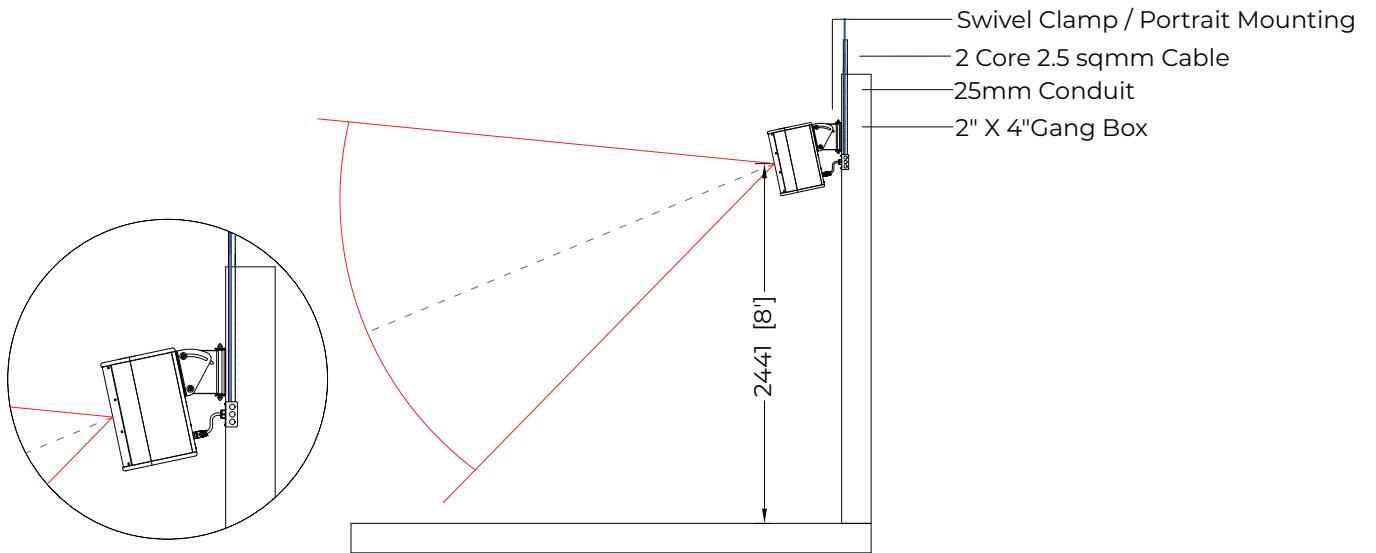

D8

Accessory Used - Swivel Clamp
Installation Type - Ceiling Mounted
Installation Mode - Portrait

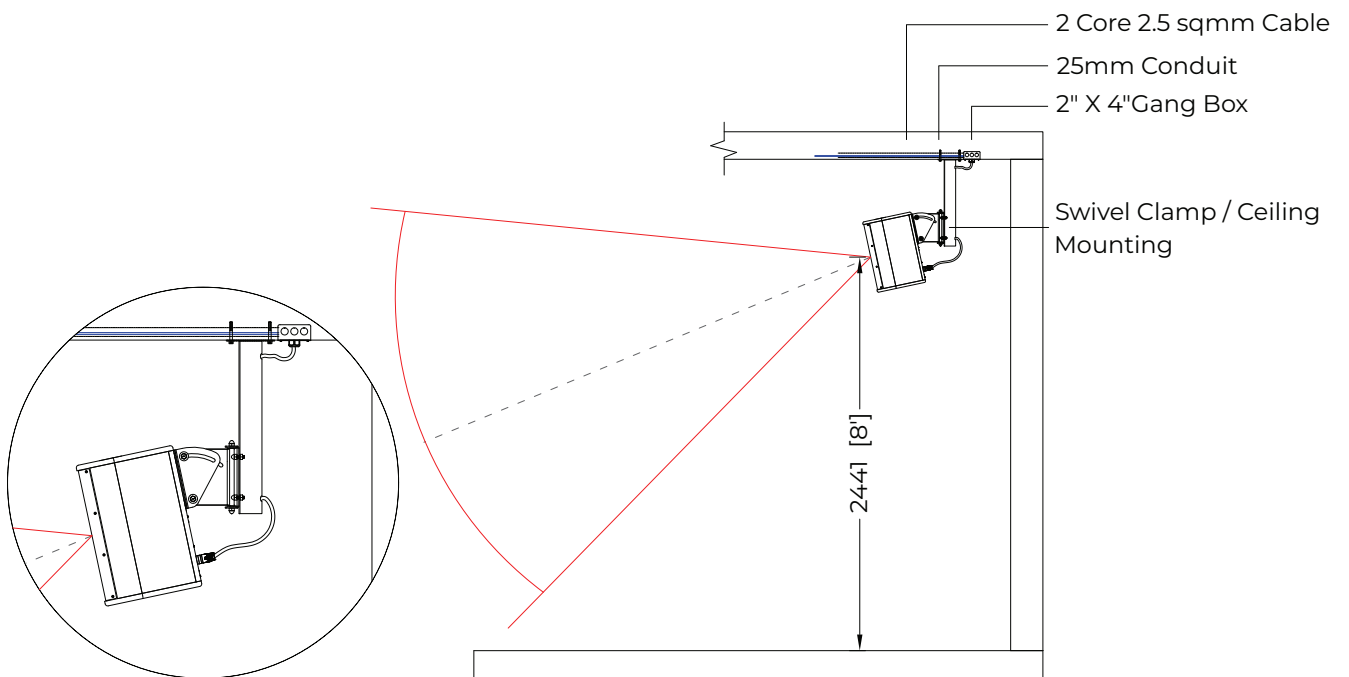

INSTALLATION DETAILS - XN 8.0.6

D9

Accessory Used - Swivel Clamp With Weatherproof Sleeve
Installation Type - Ceiling Mounted
Installation Mode - Portrait

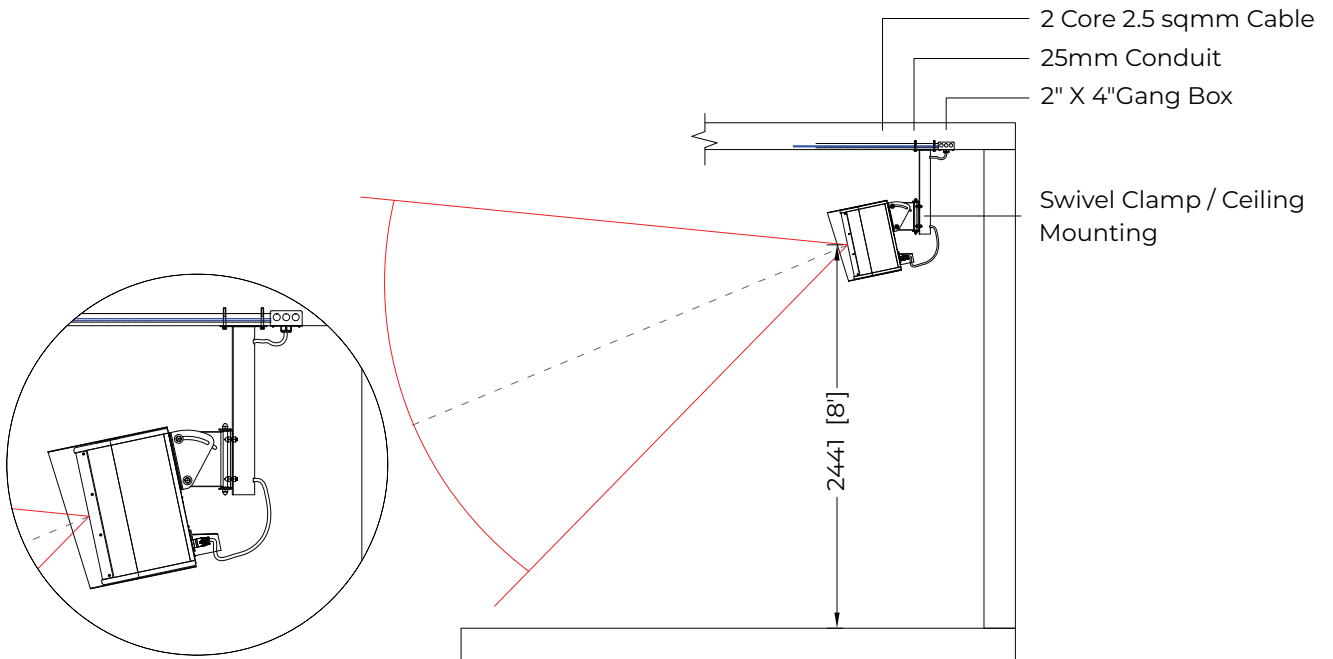

D10

Accessory Used - Swivel Clamp With Weatherproof Sleeve
Installation Type - Wall Mounted
Installation Mode - Portrait

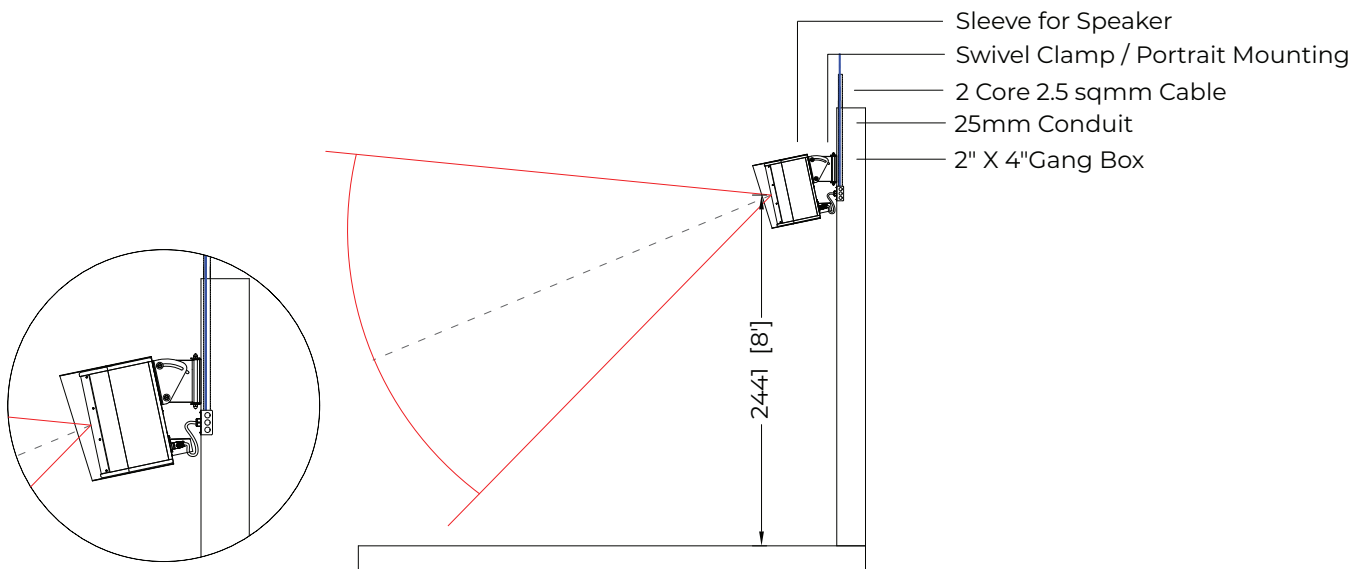

INSTALLATION DETAILS - XN 8.0.6

D11

Accessory Used - Pole
Installation Type - Pole Mounted
Installation Mode - Portrait

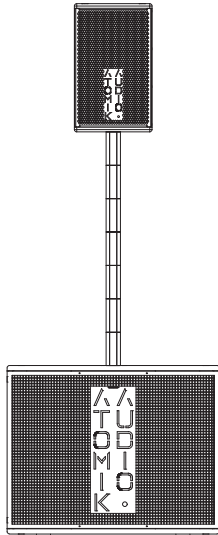

FRONT VIEW

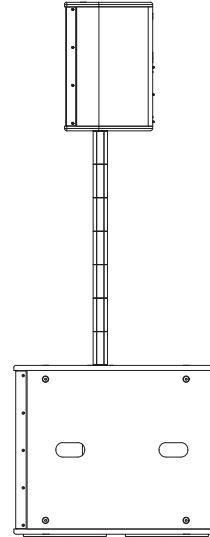

ISO VIEW

WARRANTY

Thank you for choosing the XN Series by Atomik. We take great pride in the quality and craftsmanship of our products. To ensure your satisfaction, we provide a comprehensive warranty that covers any manufacturing defects in materials or craftsmanship. Please review the details of our warranty policy to understand how we support you and your product over its lifespan.

1. Warranty Period

Atomik offers a **1-year limited warranty** for all XN Series products, starting from the date of original purchase. This warranty applies to all manufacturing defects and guarantees that the product will function as intended during this period, provided that it is used according to the guidelines in this manual.

2. Warranty Validation

To validate your warranty, you must provide proof of purchase. The original receipt or invoice is required and must show the date of purchase and the authorized dealer where the product was purchased. Warranty claims without this documentation may not be accepted.

3. Transferability of Warranty

The XN Series warranty is transferable to a subsequent owner during the warranty period. However, the warranty period will not be extended beyond the original 1-year coverage from the date of purchase. If you sell or transfer ownership of the product, the new owner will inherit the remaining warranty period, provided they also provide the original proof of purchase.

4. Coverage Details

During the warranty period, Atomik will, at its sole discretion, repair or replace any product or parts found to be defective in materials or workmanship. Warranty repairs or replacements will be carried out at no cost to the customer, except for the shipping costs associated with returning the product for service. Products must be shipped prepaid in their original packaging to an authorized Atomik service center or distributor.

5. Exclusions and Limitations

This warranty covers only defects in materials and craftsmanship. It **does not cover** the following:

- **Unauthorized Modifications:** Any modification or repair performed by a third party not authorized by Atomik will void this warranty.
- **Improper Use:** Damage or failure resulting from improper use, misuse, or use not in accordance with the guidelines in this manual.
- **Negligence or Accidents:** Any damage caused by neglect, accidents, mishandling, or misuse by the user, including physical damage, dropping, or impact.
- **Environmental Exposure:** Exposure to extreme conditions such as inclement weather, excessive heat, humidity, or moisture can damage the product and is not covered under this warranty.
- **Acts of God:** Natural events such as lightning, floods, earthquakes, or other acts of God.
- **Wear and Tear:** Normal wear and tear of parts, such as knobs, switches, and connectors, that may degrade with time or heavy usage.

6. Warranty Service Process

In the event of a defect or issue covered by this warranty, follow these steps to initiate service:

- **Contact Atomik Support:** Before returning the product, please contact our support team or authorized dealer to troubleshoot and confirm the issue.
- **Shipping and Handling:** Products being returned must be packed securely in their original packaging. Shipping charges to the service center are the responsibility of the customer. Once repaired, Atomik will cover the cost of return shipping.
- **Inspection and Repair:** Upon receipt, the product will be inspected by our technicians. If the defect is confirmed, the product will be repaired or replaced as necessary.

WARRANTY

- **Non-Warranty Repairs:** If the issue is determined to be outside of warranty coverage (due to user error or other exclusions), Atomik will provide a cost estimate for repairs. Non-warranty repairs will only be carried out with customer approval.

7. Liability Limitations

Atomik is not liable for any incidental or consequential damages, including but not limited to loss of profit, data, or usage, that may arise from the use or inability to use the XN Series products. The warranty covers the repair or replacement of the defective product only, and Atomik liability is limited to the value of the product at the time of purchase.

8. Statutory Rights

This warranty does not affect your statutory rights. Some jurisdictions do not allow limitations on how long an implied warranty lasts or the exclusion of incidental or consequential damages, so the above limitations or exclusions may not apply to you.

9. Additional Support

We are committed to providing our customers with exceptional service. If you have any questions or concerns regarding your XN Series product, please do not hesitate to contact us at [support@atomik.com] or visit our website for additional resources.

CONTACTS

Write us:

2nd Floor, No – 177, New Airport Rd, beside MANTRI SPLENDOR,
Apartment, Hiremath Layout, Hennur Gardens, Geddaiahalli,
Bengaluru, Karnataka 560077

Send us an e-mail:

support@atomikaudio.com

Visit our website:

<https://www.atomikaudio.com>

Follow us:

Instagram - <https://www.instagram.com/atomik/>