

8 7 6 5 4 3 2 1

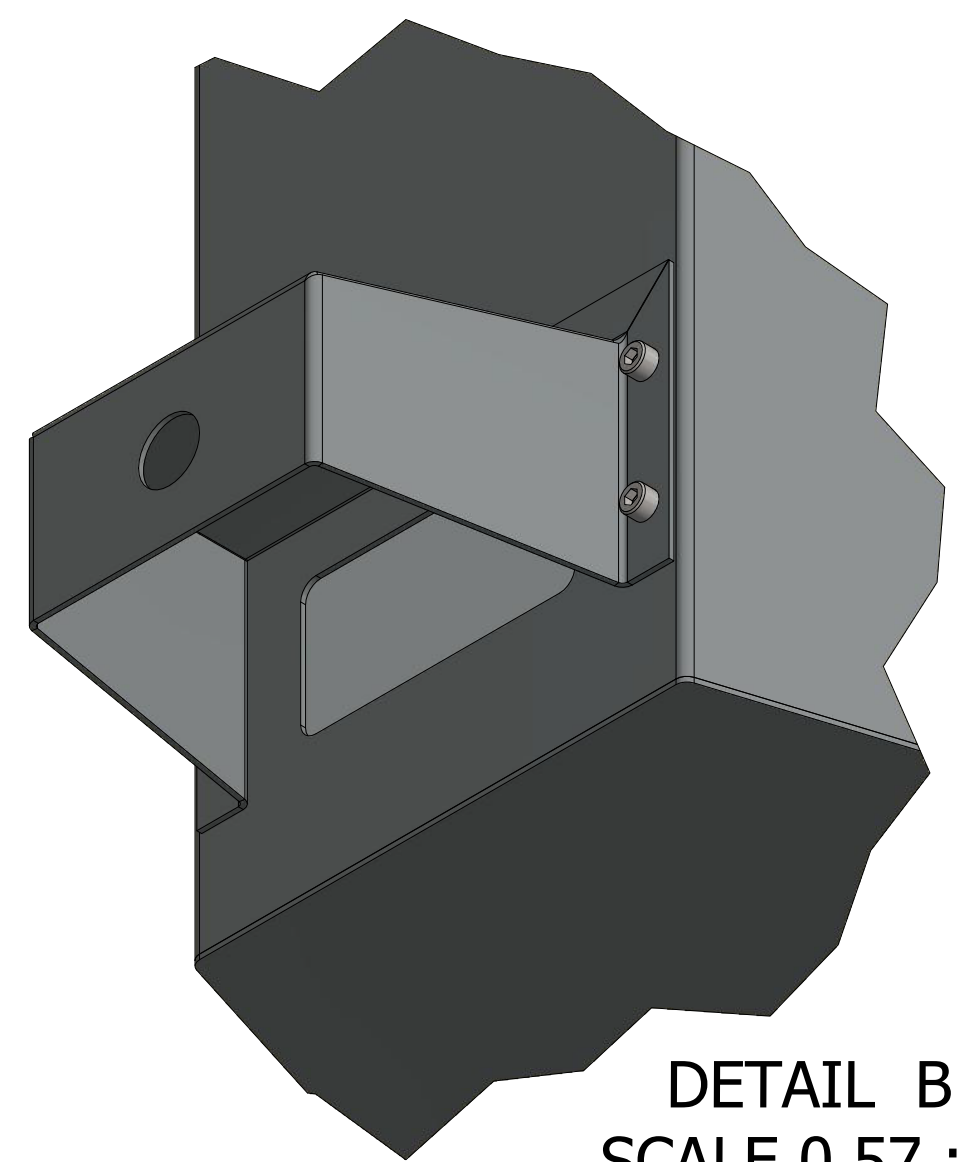

DETAIL B
SCALE 0.57 : 1

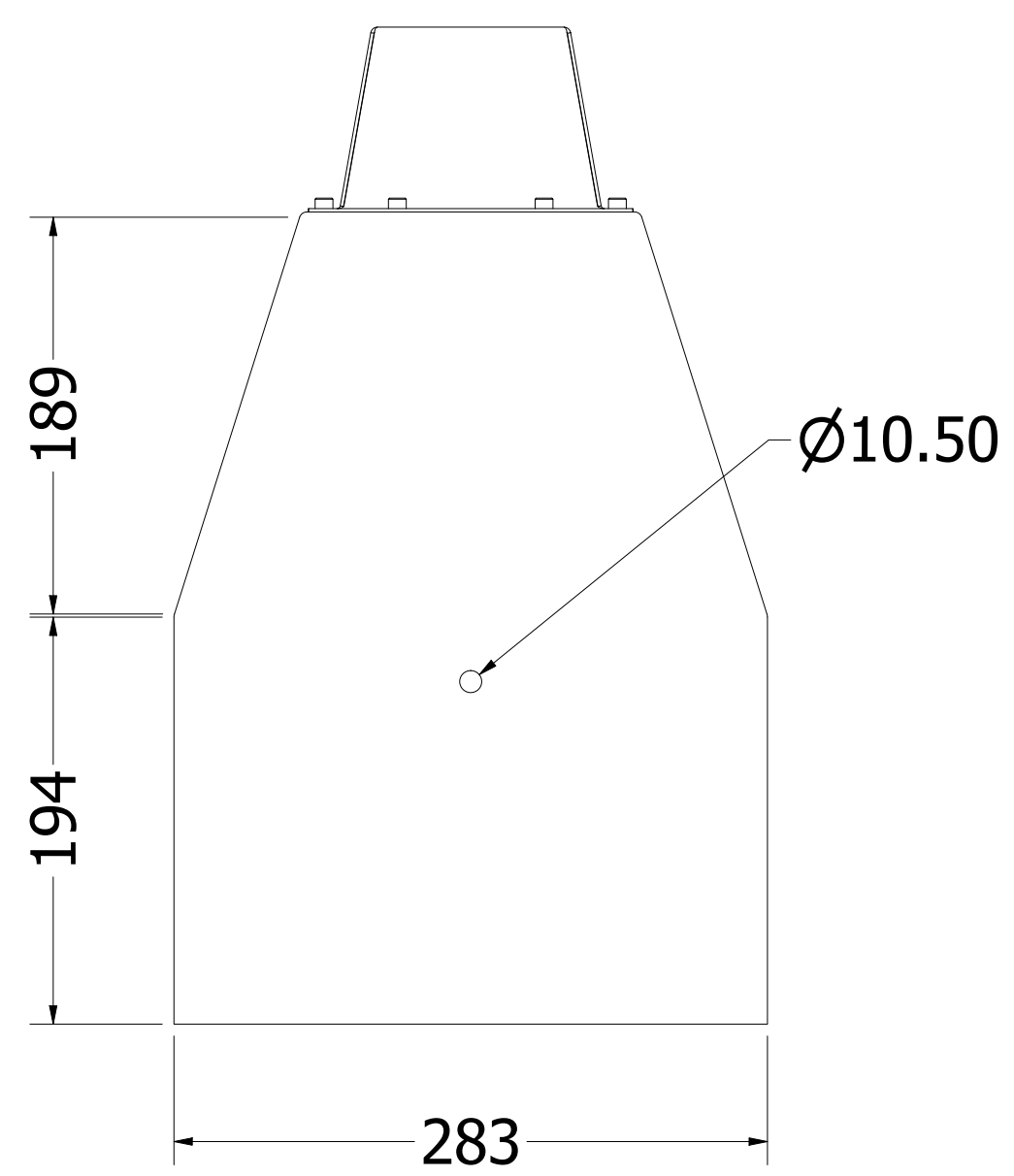
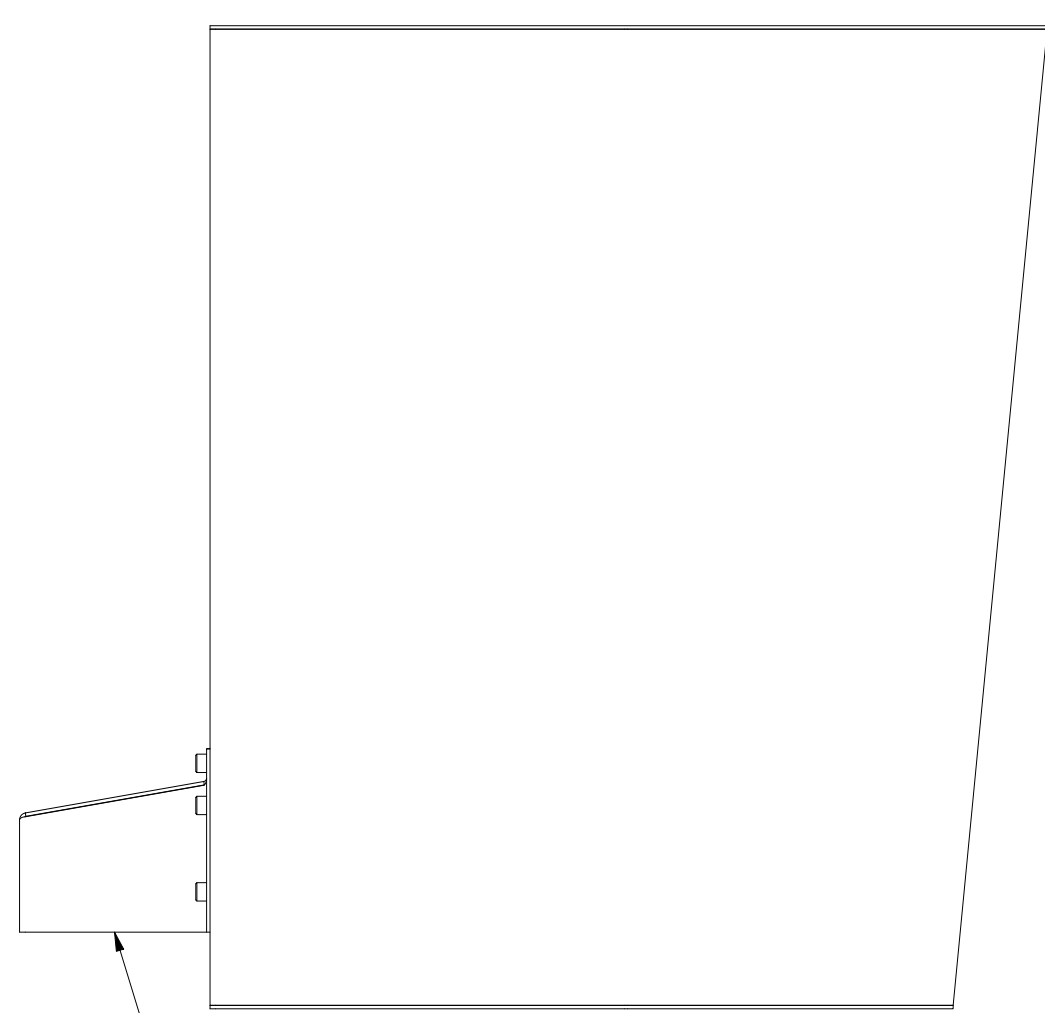
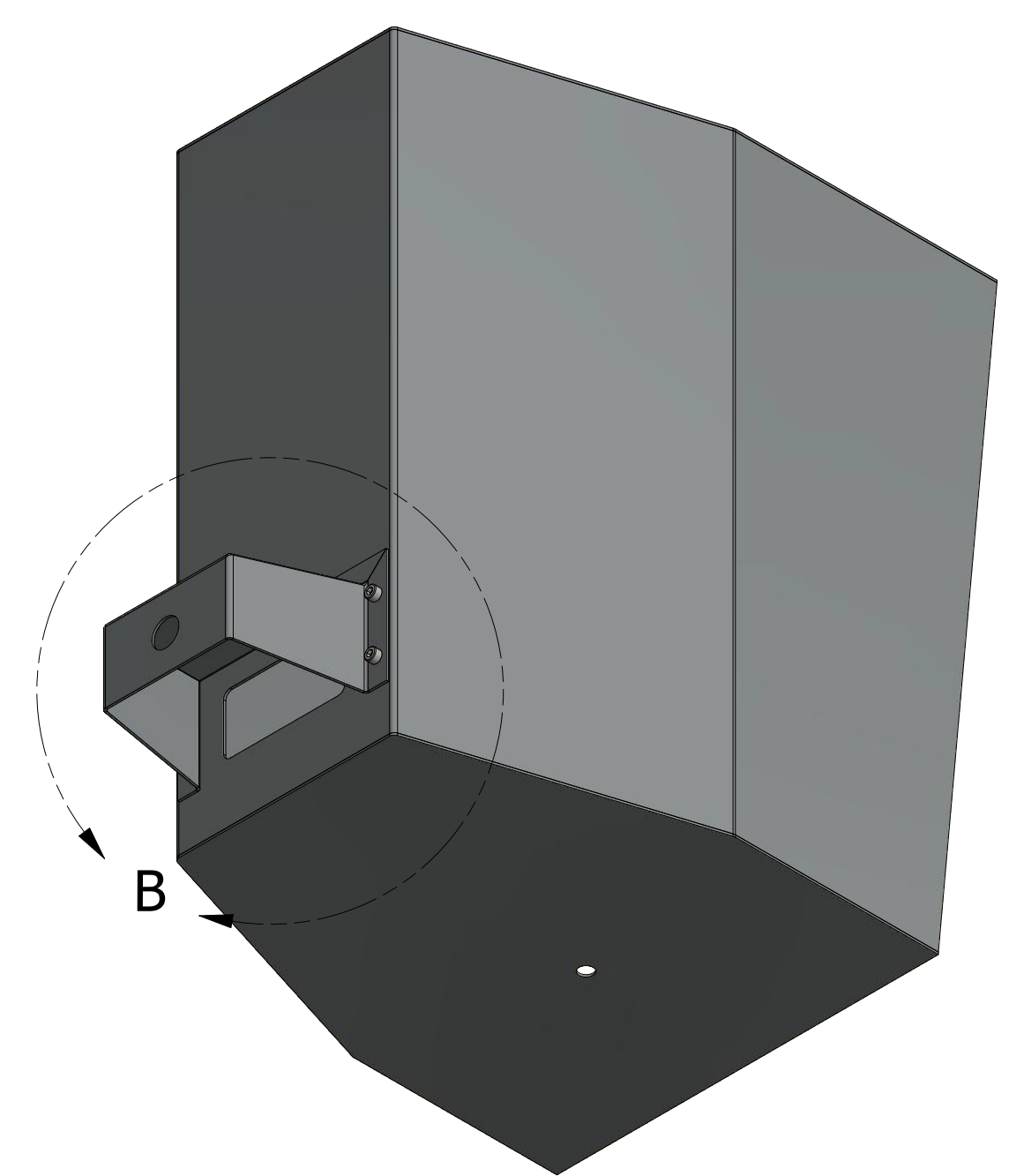
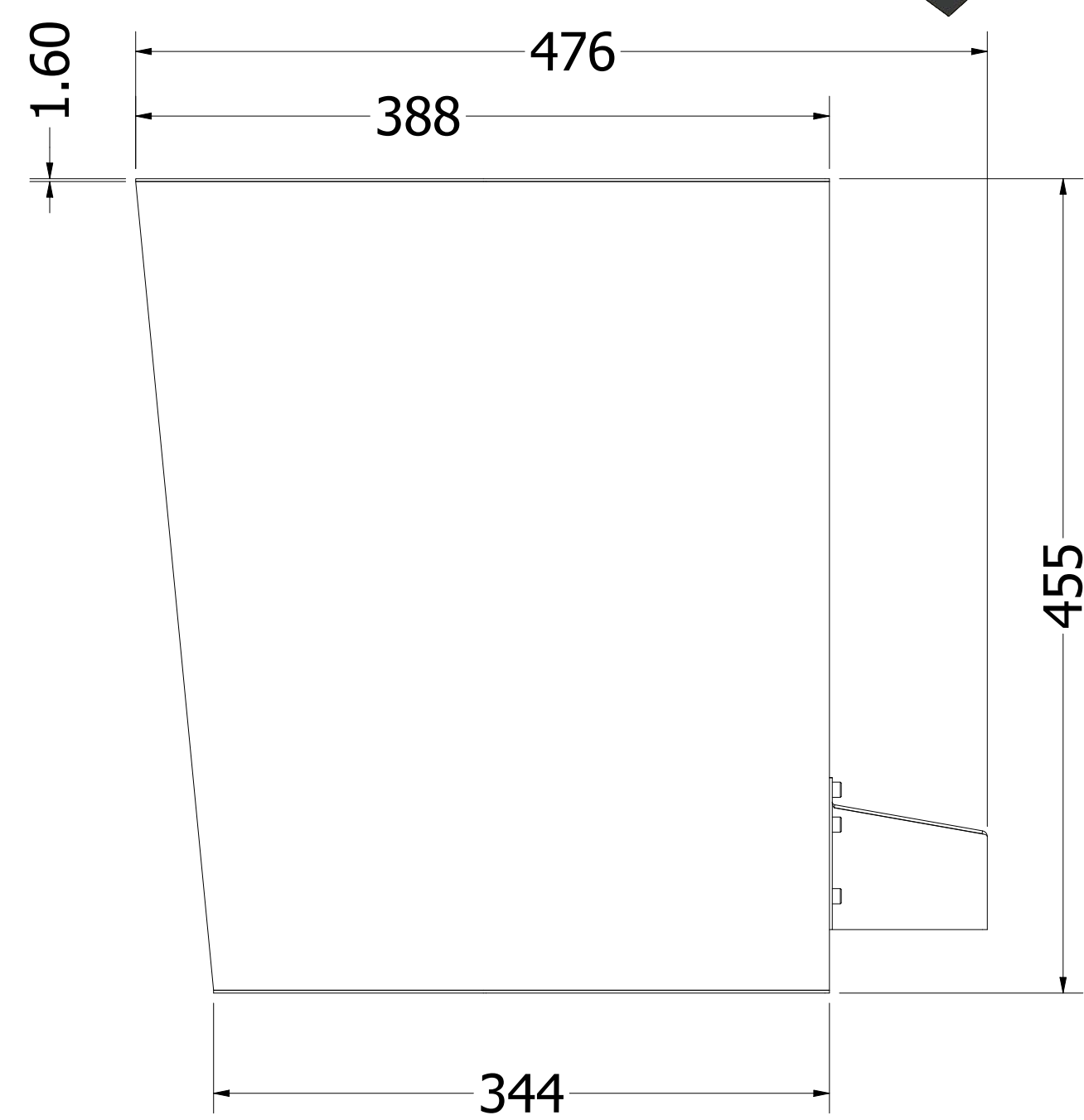
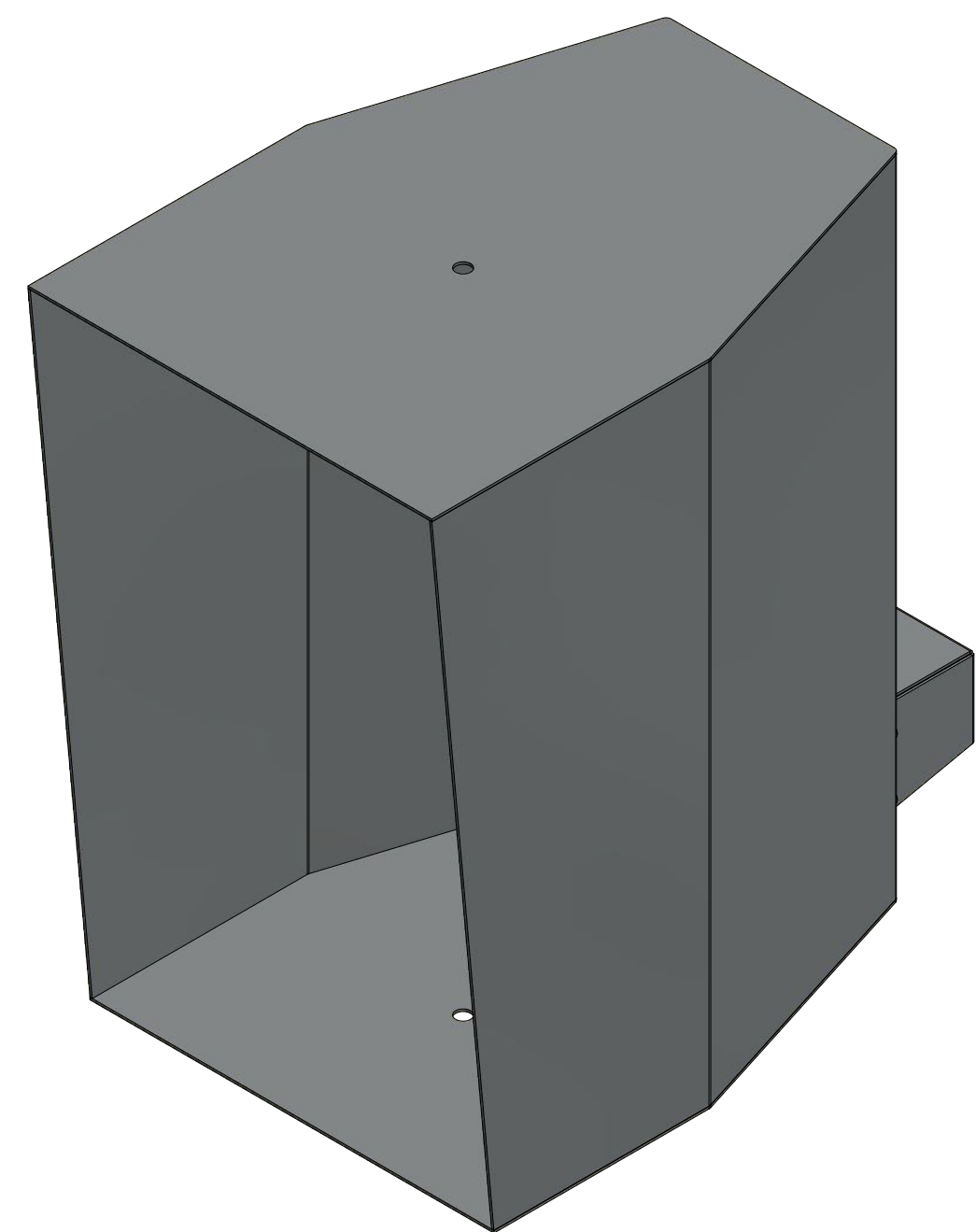

CABLE MANAGER

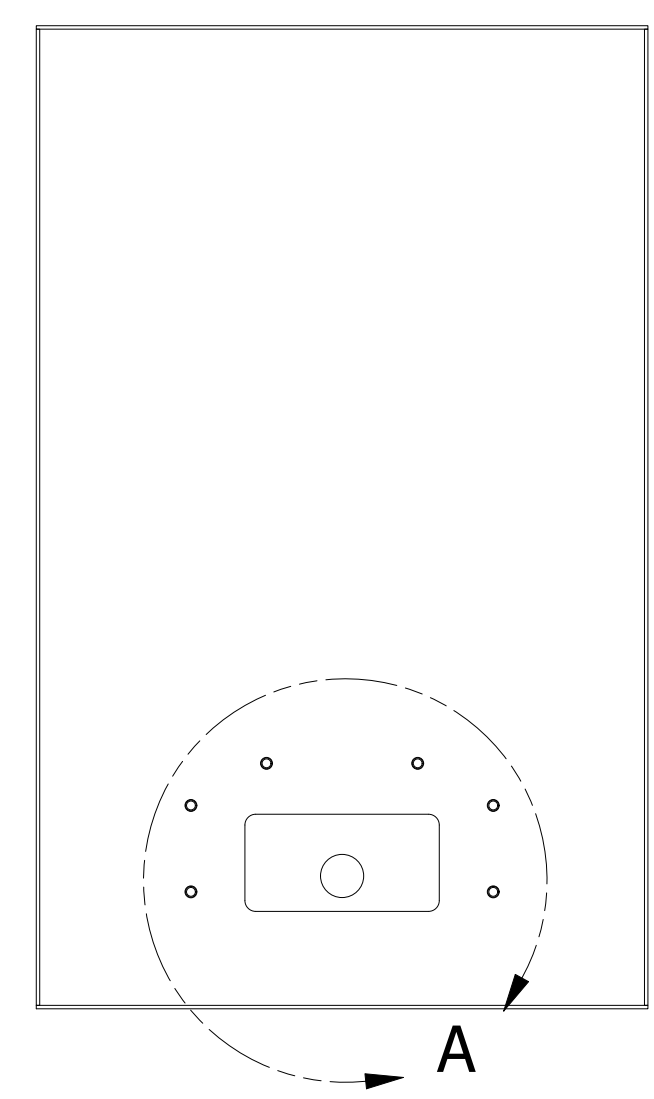

A

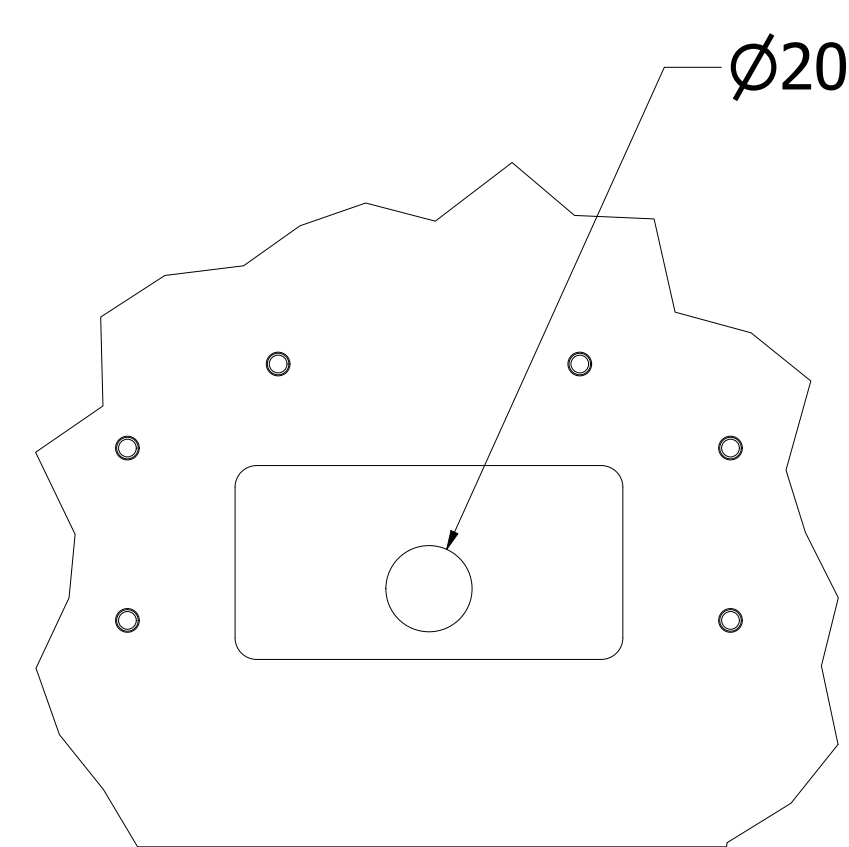

DETAIL A
SCALE 0.57 : 1

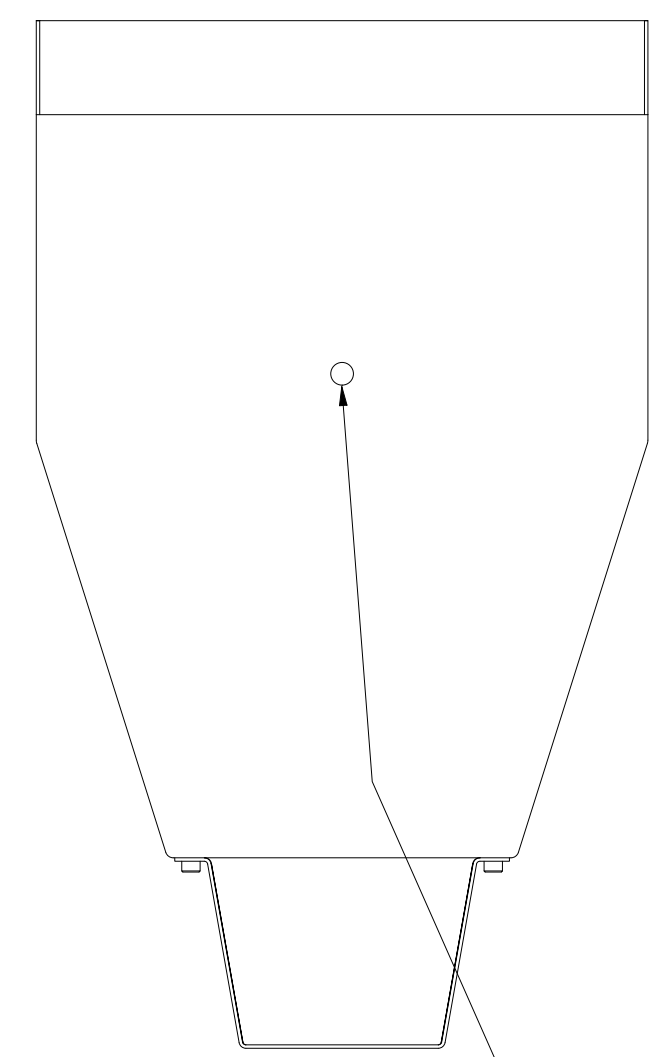

HOLE FOR INSTALLATION OF THE C CLAMP

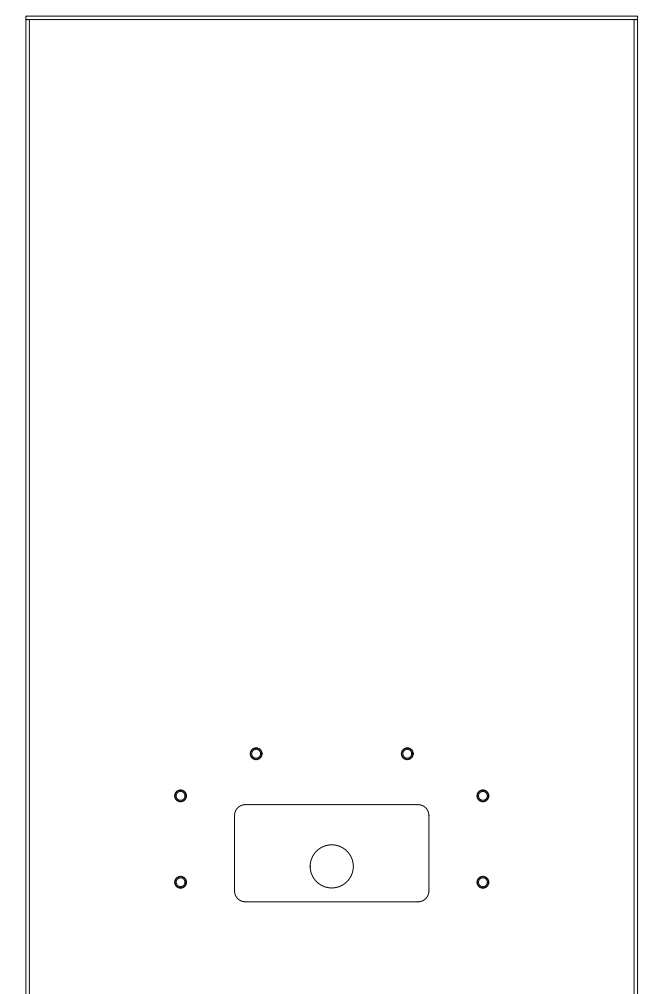

MATERIAL : 1.6mm MS Sheet.
FINISH : CUSTOM COLOR POWDER COATING

DRAWN	18-07-2024	Karma Electric, Bangalore - INDIA		
CHECKED	18-07-2024	TITLE		
QA		ATOMIK - XN 8.0.6 SLEEVE		
MFG	18-07-2024	SIZE	DWG NO	REV
APPROVED	18-07-2024	D	AA XN 8.0.6 - Sleeve V1.3_TOP	
		SCALE 1 / 3.5	SHEET 1 OF 1	

8 7 6 5 4 3 2 1